

# FIRE RESISTANCE CLASSIFICATION REPORT No. 16232C

## Owner of the classification report:

AGC Glass Europe  
166, Chaussée de la Hulpe  
B-1170 Brussels  
Belgium

## Introduction:

This classification report defines the classification assigned to a non-loadbearing glazed wall (type: Pyrobel 16\_Schüco ADS 80 FR 30 frame), in accordance with the procedures given in EN 13501-2: 2007+A1:2009: Fire classification of products and building elements – Part 2: Classification using data from fire resistance tests, excluding ventilation services.

This classification report consists of 12 pages and 9 annexes and may only be used or reproduced in its entirety.

## 1 Details of classified product

### 1.1 General

The element, Pyrobel 16\_Schüco ADS 80 FR 30 frame, is defined as a non-loadbearing glazed wall.

### 1.2 Description

The element, Pyrobel 16\_Schüco ADS 80 FR 30 frame, is fully described below in support of this classification. The drawings of the element are enclosed in the annexes 1 till 7 of this classification report.

#### 1.2.1 Composition of the test specimen:

The test specimen is a non-loadbearing glazed wall composed of glass panes in an insulated steel frame.

Dimensions of the wall:

- height: 3000 mm;
- width: 3000 mm;
- thickness: 80 mm.

##### 1.2.1.1 Glazing system:

[1]-[7] Glass panes – type: Pyrobel 16 – nominal thickness: 17.3 mm  $\pm$  1.0 mm – measured thickness: 15.7 mm till 18.1 mm.

- position: shown in annex 1;
- fixing: clasped between the glazing beads and the (intermediate) tube profiles;
- orientation: the glass panes are symmetrical.

|     | Dimensions of the glass panes:<br>(width x height) | Dimensions of the exposed area:<br>(width x height) | Reference:     |
|-----|--|---|----------------|
| [1] | 500 mm x 2888 mm                                   | 464 mm x 2852 mm                                    | CM26110-11-501 |
| [2] | 1350 mm x 2888 mm                                  | 1314 mm x 2852 mm                                   | CM26485-01-501 |
| [3] | 434.5 mm x 996 mm                                  | 398.5 mm x 960 mm                                   | CM26110-13-504 |
| [4] | 434.5 mm x 996 mm                                  | 398.5 mm x 960 mm                                   | CM26110-13-502 |
| [5] | 434.5 mm x 996 mm                                  | 398.5 mm x 960 mm                                   | CM26110-13-501 |
| [6] | 434.5 mm x 996 mm                                  | 398.5 mm x 960 mm                                   | CM26110-13-503 |
| [7] | 917 mm x 800 mm                                    | 881 mm x 764 mm                                     | CM26110-12-501 |

- [8] Setting block – material: hardwood – dimensions: 80 mm x 26 mm x 7 mm – density: 687 kg/m<sup>3</sup> (MV).
- number: two per glass pane;
  - position: under the glass pane.
- [9] Clip-on bead – brand and type: Schüco clipped beads – material: aluminium – aluminium thickness: 1.5 mm (MV) – reference: 150 830.
- position: at the exposed side;
  - fixing: clicked into the (intermediate) tube profiles.
- [10] Thermal isolation – brand and type: Schüco fireboard – material: hydrated silicate reinforced with glass fibre – outer dimensions: 26 mm x 10 mm – density: 1629 kg/m<sup>3</sup> (MV) – reference: 266 603.
- position: inside the clip-on beads.
- [11] Glazing gasket – brand and type: Schüco EPDM glazing gasket – material: rubber – thickness: 5 to 6 mm – reference: 284 305.
- position: at the exposed side;
  - fixing: clipped on the clip-on bead.
- [12] Glazing gasket – brand and type: Schüco EPDM glazing gasket – material: rubber – thickness: 4 mm – reference: 284 360.
- position: at the unexposed side;
  - fixing: clipped on the (intermediate) tube profiles.

### 1.2.2 Framing system:

The framing system includes the frame components, intumescent strip, thermal insulation and fixing parts. The exact composition of the frame is confidential and is not communicated to the laboratory.

[13] Tube profile – brand and type: Shüco profile – material: aluminium – outer dimensions: 59 mm x 80 mm – reference: 150 330.

- number: two horizontal and two vertical profiles;
- position: at the outer edges;
- fixing to the concrete frame:
  - with anchors [14] – material: steel – brand and type: Hilti 100 HT – diameter: 10 mm – length: 112 mm;
- fixing: the horizontal and the vertical profiles are welded together at the extremities;
- centre-to-centre distance: see annex 2.

[15] Anchor steel plate – brand and type: Schüco anchor steel plate – material: steel – dimensions: 57 mm x 43 mm x 1.5 mm – reference: 242 035.

- position: between the tube profile and the mineral wool;
- fixing to the tube profile:
  - clamped into the tube profile and fixed with a screw [16] – length: 15 mm – diameter: 4 mm.

[17] Intermediate tube profile – brand and type: Shüco profile – material: aluminium – outer dimensions: 84 mm x 80 mm – reference: 150 380.

- number: three horizontal and three vertical profiles;
- position: between the glass panes;
- fixing: the intermediate tube profiles are welded to the adjacent (intermediate) tube profiles.

[18] Thermal isolation – brand and type: Schüco fireboard – material: hydrated silicate reinforced with glass fibre – dimensions: 30 mm x 34 mm – density: 1629 kg/m<sup>3</sup> (MV) – reference: 298 426.

- position: inside the (intermediate) tube profiles.

[19] Glazing clip – brand and type: Schüco glazing clip – material: steel – reference: 242 860.

- position: between the (intermediate) tube profiles and the glass panes (see annex 7).
- centre-to-centre distance: 200 mm to 380 mm (see annex 7)

- [20] Retaining clip – brand and type: Schüco retaining clip – material: steel – reference: 242 861.
- position: clicked on top of the glazing clip to clamp the glass pane between the retaining and glazing clip.
- [21] Fixing plate – brand and type: Schüco fixing plate – material: steel – reference: 242 033.
- position: on top of the glazing clips where an anchor is used;
  - fixing: clamped between the screw head of the anchor and the glazing clip.
- [22] Intumescent strip – material: graphite-based – section dimensions: 27 mm x 2 mm – reference: 266 784.
- position: around the extremities of the glass panes on the (intermediate) tube profiles;
  - fixing: self-adhesive to the (intermediate) tube profiles.
- [23] Setting block – material: calcium silicate – dimensions: 260 mm x 55 mm x 15 mm – density: 960 kg/m<sup>3</sup> (NV).
- position: under the steel frame;
  - centre-to-centre distance: 800-1000 mm.
- [24] Mineral wool – brand and type: Thermal insulation Promat Promaglaf HTK 1100 – initial thickness: 25 mm – initial density: 96 kg/m<sup>3</sup> (NV).
- position: between the tube profiles and the concrete frame, at the fixed edges.

## 2 Test reports/EXAP-reports and test results in support of the classification

### 2.1 Test reports/EXAP-reports

| Name of the laboratory | Report ref. no. | Name of the owner | Date of the test | Method                             |
|------------------------|-----------------|-------------------|------------------|------------------------------------|
| WFRGENT nv             | 16232A          | AGC Glass Europe  | 11/10/2013       | EN 1364-1:1999<br>FprEN1364-1:2012 |
| WFRGENT nv             | 16232B          | AGC Glass Europe  | -                | EN 15254-4:2008+A1:2011            |

#### Exposure conditions during the fire resistance test:

Temperature/time curve: standard as in EN 1363-1:2012.

Direction of exposure: The glazing system is symmetrical.  
The framing system is asymmetrical: glazing beads at the exposed side.

No load was applied.

One vertical edge is free, the other edges are fixed.

### 2.2 Test results

| Parameters                                 | Results                               |
|--|---------------------------------------|
| <b>Thermal insulation – I</b>              |                                       |
| $\Delta T_m = 140^\circ\text{C}$           | 37 minutes                            |
| $\Delta T_M = 180^\circ\text{C}$           | 36 minutes                            |
| <b>Integrity – E</b>                       |                                       |
| Spontaneous and sustained flaming          | 48 minutes                            |
| Failure with gap gauge $\varnothing$ 6 mm  | 48 minutes, no failure <sup>(2)</sup> |
| Failure with gap gauge $\varnothing$ 25 mm | 48 minutes, no failure <sup>(2)</sup> |
| Ignition of cotton pad                     | 48 minutes, no failure <sup>(2)</sup> |
| <b>Radiation – W</b>                       |                                       |
| Radiation intensity = 15 kW/m <sup>2</sup> | 48 minutes, no failure <sup>(1)</sup> |

<sup>(1)</sup> The test was stopped after 48 minutes for safety reasons.

<sup>(2)</sup> No failure until spontaneous and sustained flaming.

### 3 Classification and field of application

#### 3.1 Reference of classification

This classification has been carried out in accordance with clause 7 of EN 13501-2:2007+A1:2009.

#### 3.2 Classification

The element, Pyrobel 16\_Schüco ADS 80 FR 30 frame, is classified according to the following combinations of performance parameters and classes as appropriate. No other classifications are permitted.

The classifications are only valid for the direction of exposure, as described in § 2.1.

**EI 30, EI 20, EI 15**

**EW 30, EW 20**

**E 30, E 20**

#### 3.3 Field of direct application

This classification is valid for the following end use applications according to EN 1364-1:1999.

The results of the fire test are directly applicable to similar constructions where one or more of the changes listed below are made and the construction continues to comply with the appropriate design code for its stiffness and stability:

- a) unlimited increase and decrease of the width of the wall;
- b) unlimited decrease in height of the wall of 3 m;
- c) decrease in the linear dimensions of panes;
- d) change in the aspect ratio of panes provided that the largest dimension of the pane and its area are not increased;
- e) decrease in the distance between mullions and transoms;
- f) decrease in distance between fixing centres;
- g) increase in the dimensions of framing members;
- h) the use of screwed-on glazing beads;

- i) allowances for expansion;
- j) change in the angle of installation of up to 10° from the vertical.

### **3.4 Field of extended application**

This classification is valid for the following end-use applications according to EN 15254-4:2008+A1:2011.

The results of the fire test are directly applicable to similar constructions where one or more of the changes listed below are made. Other changes are not permitted.

#### **3.4.1 Exchange of the fire resistant glass**

The “pyrobel 16” glass panes can be replaced by thicker “pyrobel” glass panes, considering the rules listed in extended application report 16232B.

#### **3.4.2 (A)symmetrical fire resistant glass**

The fire resistant glass is symmetrical and can be used in both directions.

#### **3.4.3 Individual rectangular glass panes: integrity and terminal insulation**

The maximum dimensions of the circular, triangular and four sided shaped glass panes are represented by the thickest lines in annex 8, for the indicated E and EI classifications.

The maximum dimensions of the other non-rectangular glass panes are represented by the thinnest lines in annex 8, for the indicated E and EI classifications.

#### **3.4.4 Individual rectangular glass panes: radiation**

The maximum dimensions of the circular, triangular and four sided shaped glass panes are represented by the thickest lines in annex 8, for the indicated EW classifications.

The maximum dimensions of the other non-rectangular glass panes are represented by the thinnest lines in annex 8, for the indicated EW classifications.



### 3.4.5 Exchange of metal glazing beads

It is not allowed to exchange the type of material used for the glazing beads.

Changes in bead shape are only allowed if it can be demonstrated not to have a detrimental effect on the fire performance.

Clipped beads can be replaced by screw fixed or riveted beads.

Bead depth can be increased (see schematic drawing 1, item 7). The bead depth must be at least 49 mm.

The bead height can be increased provided that the edge cover doesn't change or the increase in edge cover can be shown, that it does not have a detrimental effect on the fire performance. The bead height must be at least 25 mm.

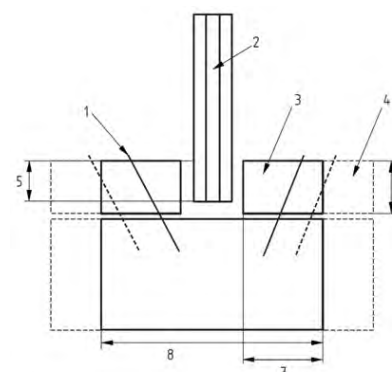

#### Key

- 1 bead fixing e.g. screws, nails etc;
- 2 glass;
- 3 bead;
- 4 bead extended in depth;
- 5 edge cover;
- 6 bead height;
- 7 bead depth;
- 8 frame section depth.

Schematic drawing 1

### 3.4.6 Exchange of glazing materials

Except for glazing beads, exchange of one glazing material (Gaskets/glazing, strips/setting blocks, ...) for another is allowed. But only if it can be demonstrated that the exchange does not have a detrimental effect on the fire performance within a comparable glazing system of the same product group.

### 3.4.7 Bead surface coverings

Decorative surface coverings of the glazing beads may be added where one does not exist, provided it can be demonstrated that the covering material achieves at least Class A2 when tested according to EN 13501-1. In addition it must be shown that they do not adversely affect the fire resistance performance of the fire resistant glazed element.

If the surface covering is not Class A2 then it has to be proven that it does not negatively affect the fire performance.

Any coverings on glazed elements classified EI shall be secured using only fixing method(s) proven in the reference test and/or by previously existing test data.

### 3.4.8 (A)symmetrical framing systems

The framing system is asymmetrical and can only be used in the direction it was tested: glazing beads at the exposed side.

### 3.4.9 Exchange of frames

Frames can be manufactured using all or some of the following allowed junction types:

- |                    |   |
|--------------------|---|
| type A is allowed: | four panes joining together;  |
| type B is allowed: | three panes joining together at one point including a full height vertical pane;  |
| type C is allowed: | three panes joining together at one point including a full width horizontal pane; |
| type D is allowed: | two full panes side by side;  |
| type E is allowed: | corner junction.  |

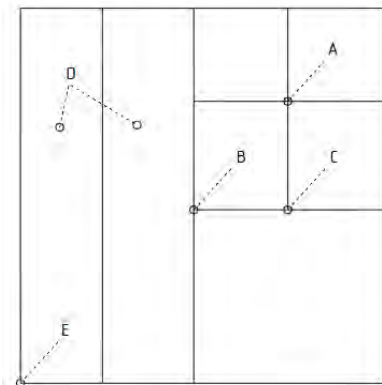

Schematic drawing 2

### 3.4.10 Metal frames

It is not allowed to exchange the type of material used to construct the frame.

The frame section may be changed provided that it can be demonstrated that:

- the axial stress levels in the vertical elements and the bending stress are not increased in cold state;
- the HP/A factor for the frame and bead is not increased; (HP = Heated perimeter [mm]; A = Heated cross section [mm<sup>2</sup>])
- the depth of the section is not reduced;
- the wall thickness and number of chambers in the frame are not reduced.

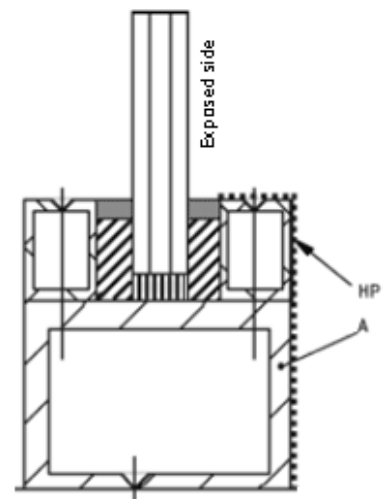

Schematic drawing 3

### **3.4.11 Frame surface coverings**

Decorative surface coverings of the framing members may be added where one does not exist, provided it can be demonstrated that the covering material achieves at least Class A2 when classified according to EN 13501-1. In addition it must be shown that they do not adversely affect the fire performance of the fire resistant glazed partition, e.g. in the case of replacement of coverings that provide a contribution to insulation performance.

Any coverings on glazed partitions classified EI shall only be secured using fixing methods that do not impair the fire performance of the partition.

### **3.4.12 Increase in overall dimensions and area of the partition**

The maximum overall dimensions of the fire resistant glazed partition are represented by the thickest lines in annex 9, for the indicated E and EI classifications.

### **3.4.13 Increase in dimensions for the fire resistant glazed partitions: radiation**

The maximum overall dimensions of the fire resistant glazed partition are represented by the thickest lines in annex 9, for the indicated EW classifications

### **3.4.14 Replication of the fire resistant glazed partition with reference to radiation**

A wider construction achieved by replicating the fire resistant glazed partition as tested, by adding more units of the same fire resistant glazed partition side by side is allowed for the classifications listed in paragraph 3.2.

### **3.4.15 Changing in installation angle**

A change in the angle of installation of up to  $\pm 10$  degrees from the vertical is allowed. No further increase in the installation angle is allowed.

#### 4 Limitations

This classification document does not represent type approval nor certification of the product.

SIGNED

APPROVED

This document is the original version of this classification report and is written in English.

This report may be used only literally and completely for publications. For publications of certain texts, in which this report is mentioned, our permission must be obtained in advance.

The authenticity of the electronic signatures is assured by Belgium Root CA.

Front view (unexposed side) - dimensions

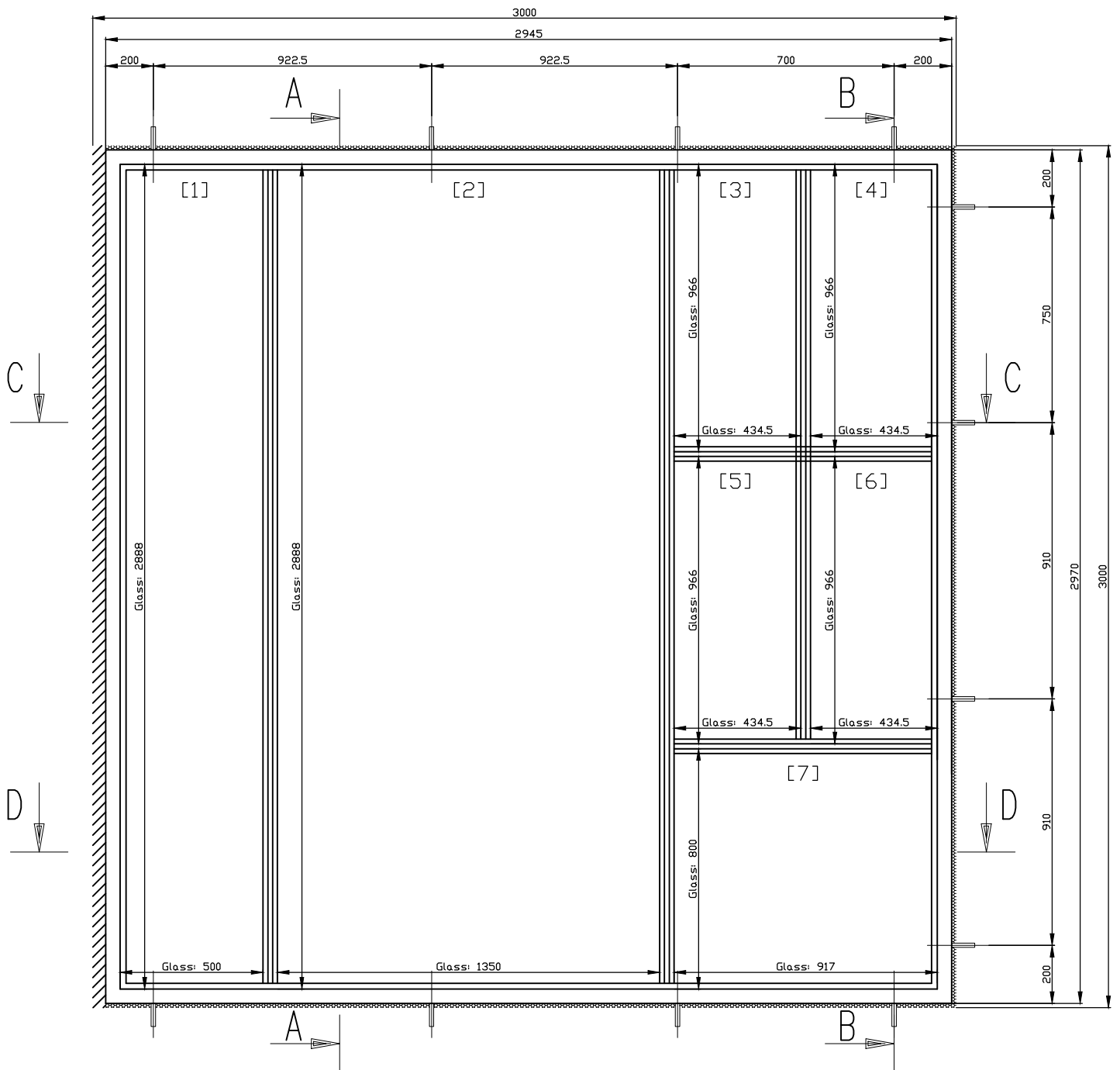

Dimensions in mm.

Section A-A - dimensions

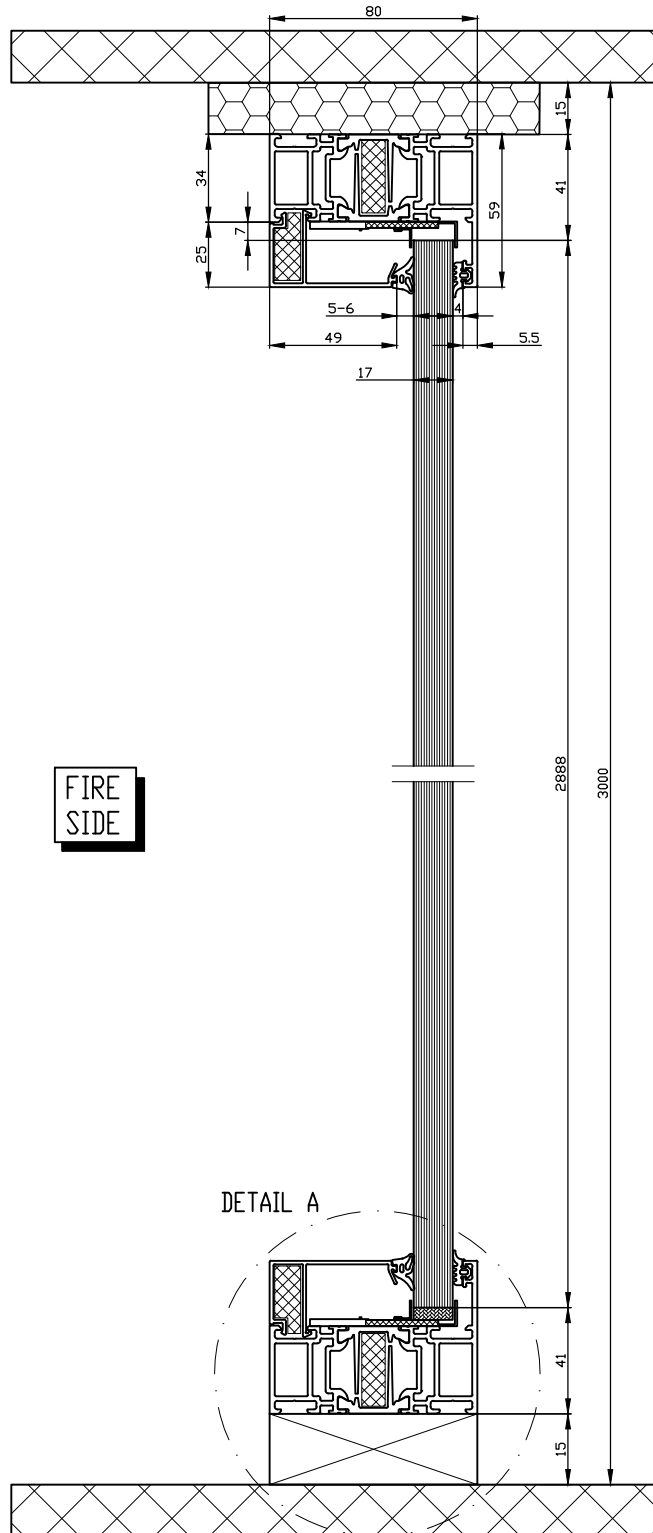

Dimensions in mm.



Section C-C - dimensions

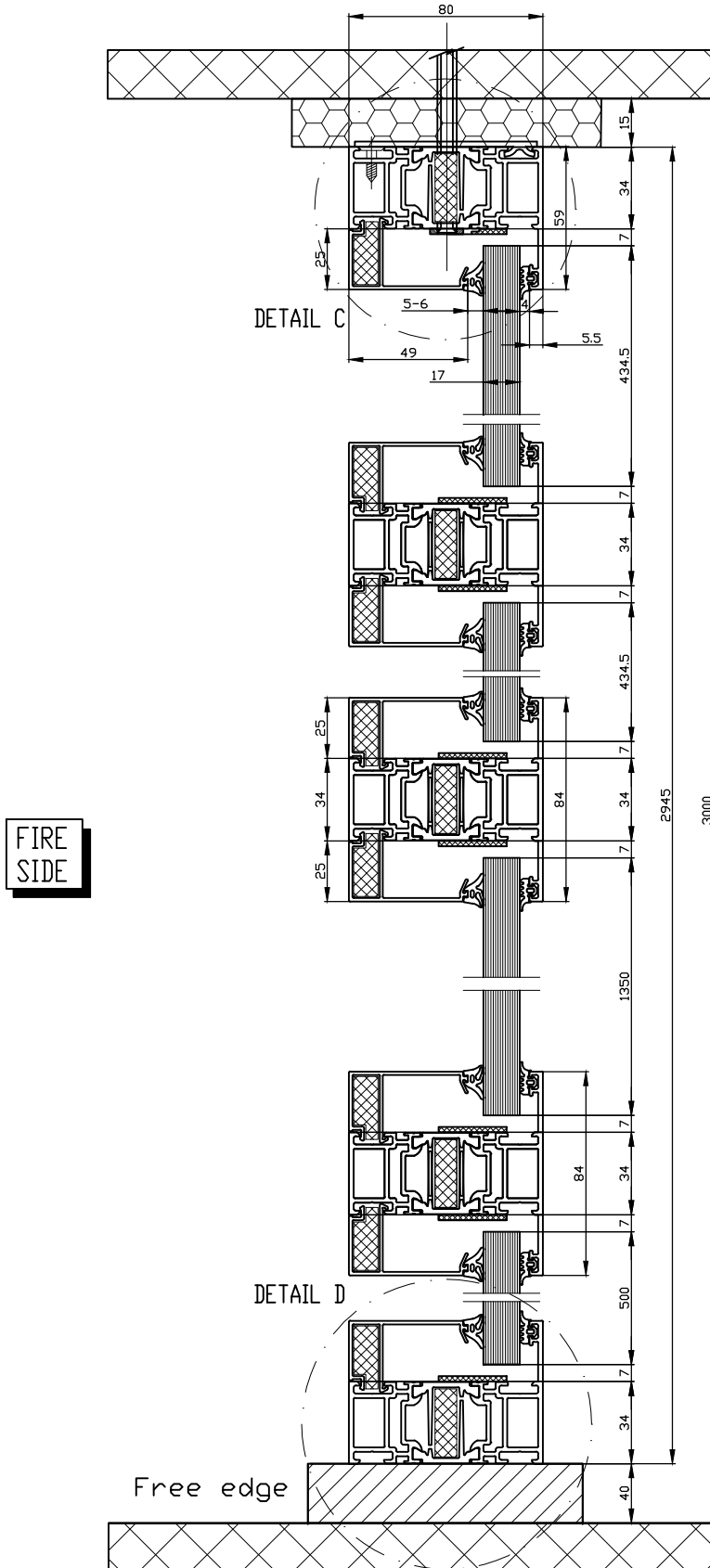

Dimensions in mm.



Section D-D - dimensions

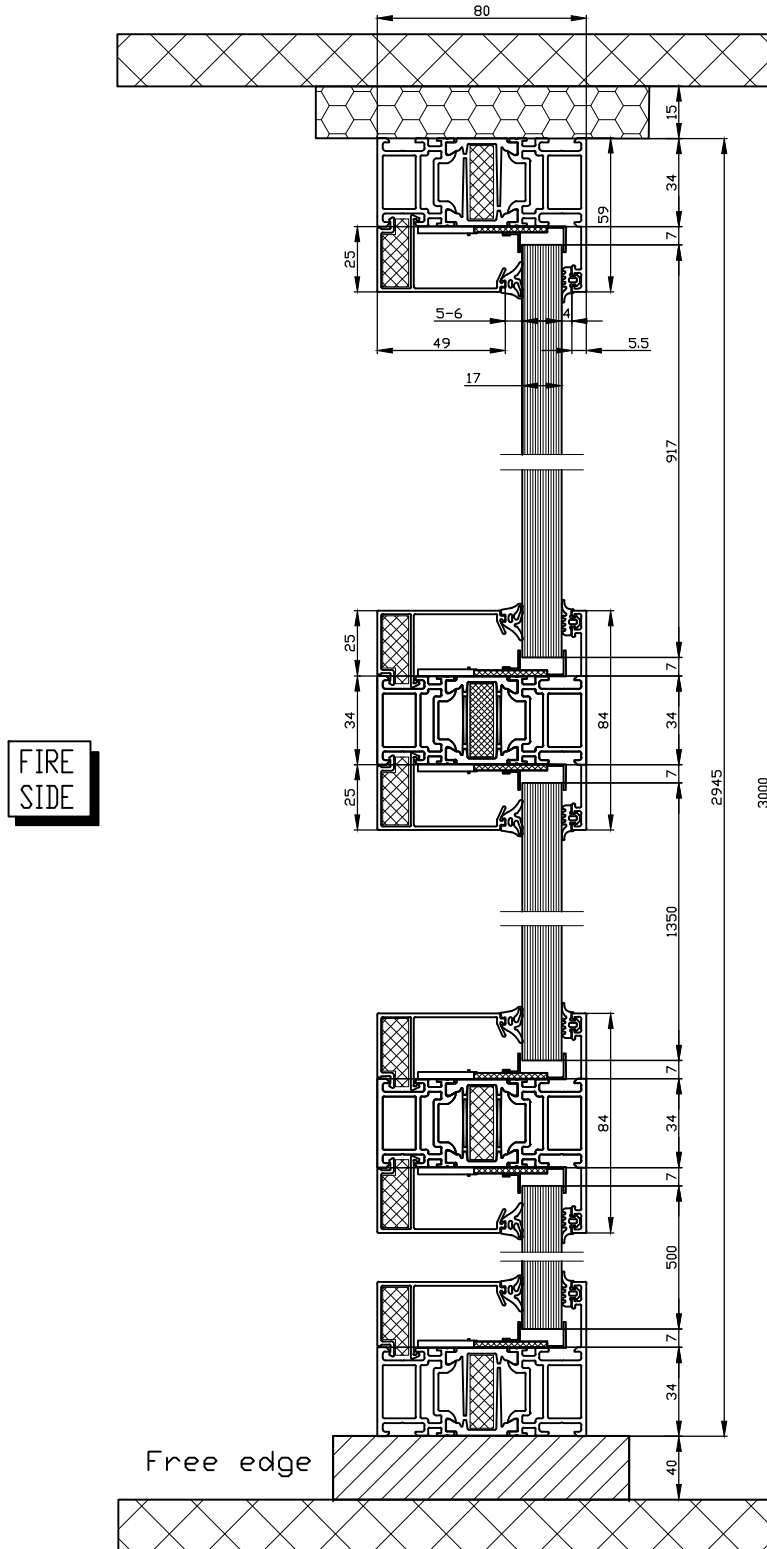

Dimensions in mm.

Position of the glazing and retaining clips [19] and [20]

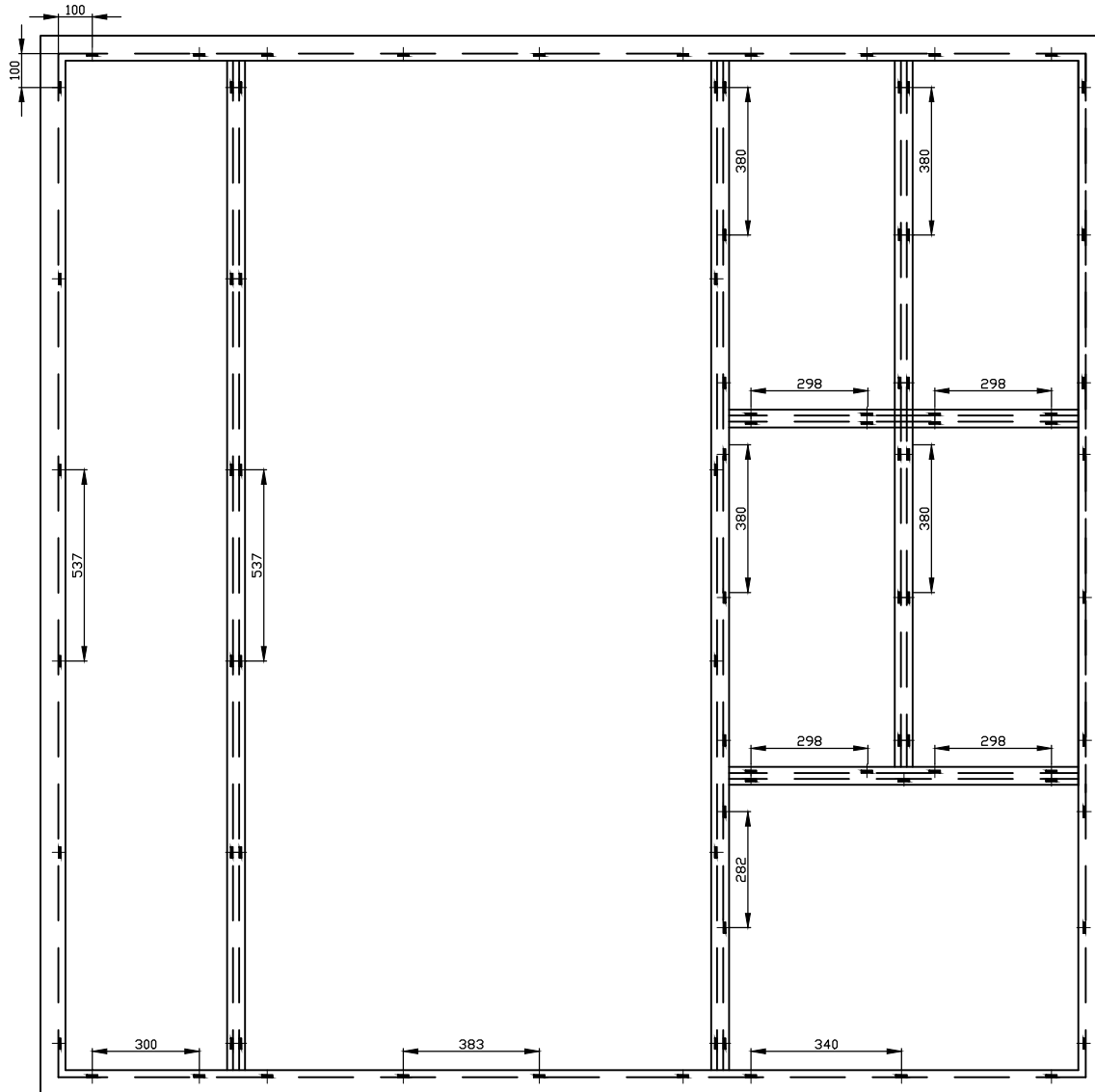

Positioned at 100 mm from each corner of each glass.  
The rest are divided at equal distance from each other as given  
in the drawing.

Details

DETAIL A

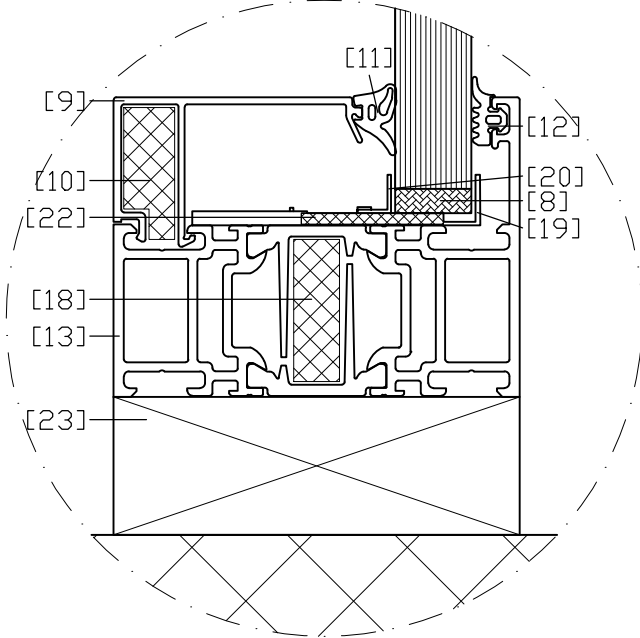

DETAIL B

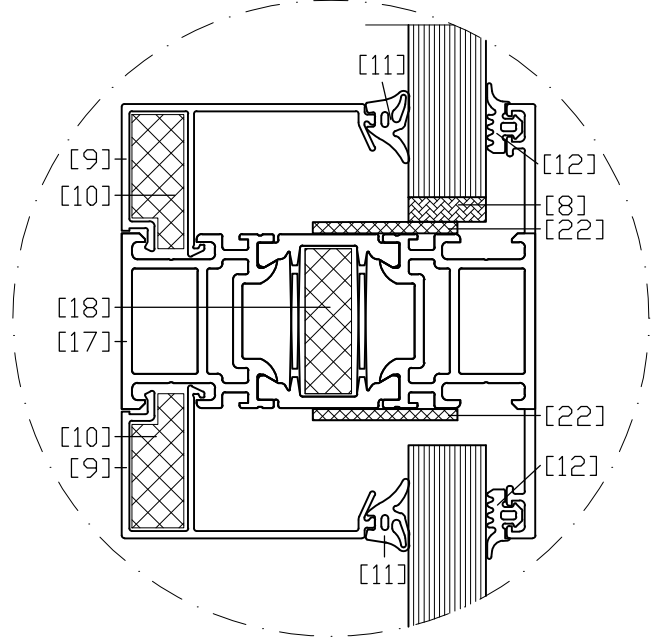

DETAIL C

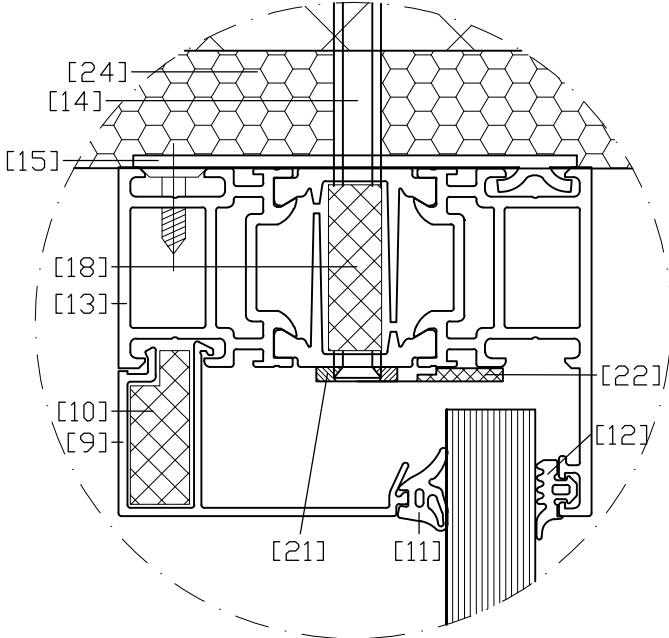

DETAIL D

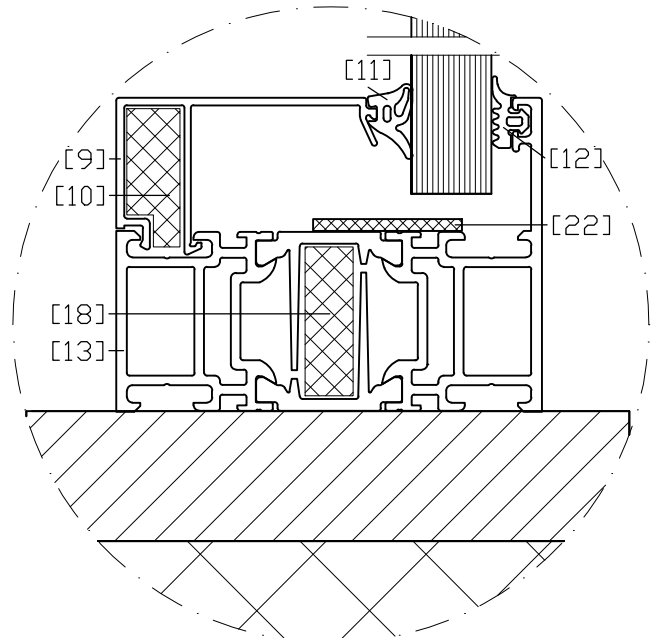

**Individual rectangular glass panes: aspect ratio and increase in area**

The extended dimensions are only valid for the following classifications:

- EI 30, EI 20, EI 15;
- E 30, E 20;
- EW 30, EW 20.

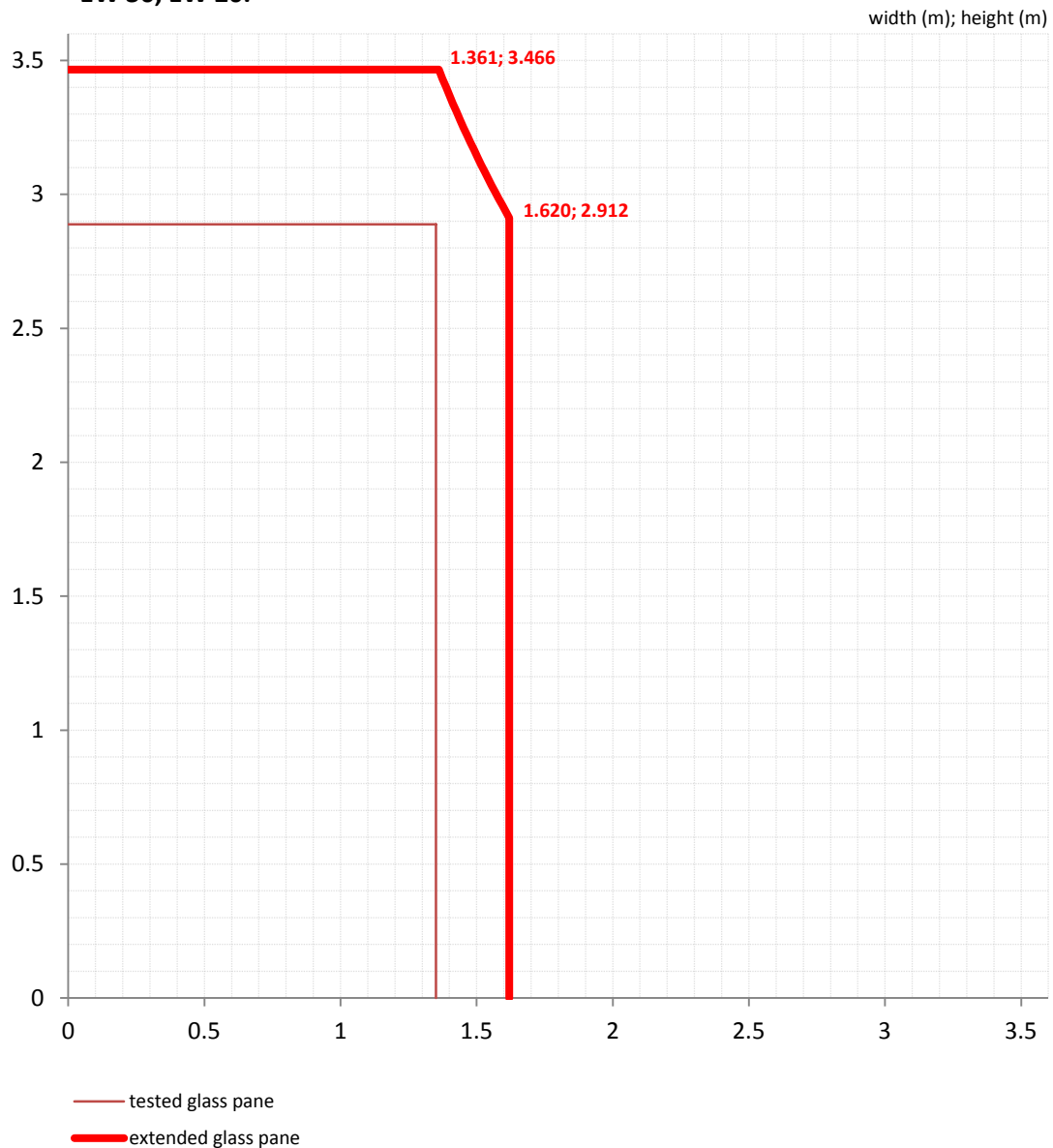

**Note:**

The maximum dimensions of circular, triangular and four sided shaped glass panes are represented by the thickest lines (extended dimensions). The maximum dimensions of the other non rectangular glass panes are represented by the thinnest lines (tested dimensions).

### Increase in overall dimensions and area of the partition

The extended dimensions are only valid for the following classifications:

- EI 30, EI 20, EI 15;
- E 30, E 20;
- EW 30, EW 20.

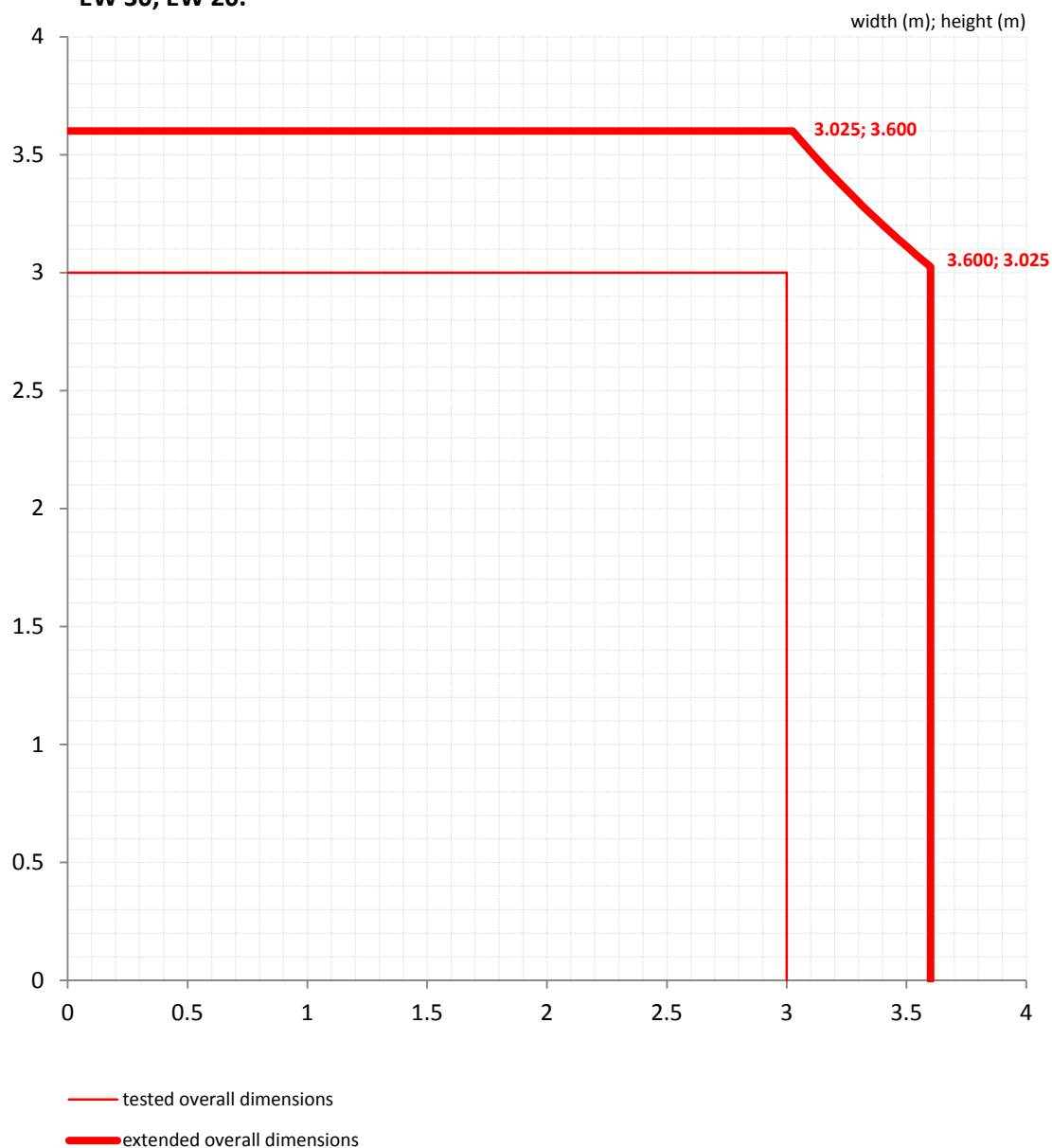

#### Note:

The maximum overall dimensions of the fire resistant glazed partition are represented by the thickest lines. A wider construction achieved by replicating the extended fire resistant glazed partition is allowed.