

# FIRE RESISTANCE CLASSIFICATION REPORT No. 14891D

## Owner of the classification report:

AGC Glass Europe  
166, Chaussée de la Hulpe  
1170 Brussels  
BELGIUM

## Introduction:

This classification report defines the classification assigned to a non-loadbearing glazed wall – type: Pyrobelite 7 IGU (Pyrobelite 7-air 15-44.2)\_Timber frame\_silicone – in accordance with the procedures given in EN 13501-2:2007+A1:2009: Fire classification of products and building elements – Part 2: Classification using data from fire resistance tests, excluding ventilation services.

This classification report consists of eleven pages and seven annexes and may only be used or reproduced in its entirety.

## Details of classified product

### 1.1 General

The product is defined as a non-loadbearing wall – type: Pyrobelite 7-air 15-44.2)\_Timber frame\_silicone. It is evaluated in respect of the fire performance characteristics given in clause 5 of EN 13501-2:2007+A1:2009.

### 1.2 Product description:

The test element, type: Pyrobelite 7 IGU (Pyrobelite 7-air 15-44.2), including edge and boundary conditions, is fully described below in support of classification. The drawings of the test report are enclosed in the annexes 1 till 5.

#### Composition of the tested glazed wall:

The unloaded glazed wall is composed of glass panes in a timber frame.

#### 1.2.1 Glazing system:

The glazing system consists of glass panes [1]-[6], setting blocks [7], timber glazing beads [8], bead fixings [9], intumescent glazing strips [10], sealants [11] and intumescent strips [12]. The exact composition of the glass panes is confidential and is communicated to the laboratory.

- [1]-[6] Glass panes – brand and type: Pyrobelite 7 IGU (Pyrobelite7-air15-44.2) – nominal glass thickness:  $31.7 \pm 2.0$  mm – measured thickness: 31.0 mm.
- position: shown in annex 1.
  - fixing: clasped between glazing beads on both sides.
  - orientation: the glass panes are asymmetrical; each pane is placed with the PVB- layer (type 44.2) at the exposed side.

	Dimensions of the panes: (Width x Height)	Dimensions of the exposed area: (Width x Height)	Reference:
[1]	1027 mm x 956 mm	983 mm x 912 mm	CM20652-32-501
[2]	700 mm x 956 mm	656 mm x 912 mm	CM20650-33-502
[3]	1027 mm x 956 mm	983 mm x 912 mm	CM20650-32-502
[4]	700 mm x 956 mm	656 mm x 912 mm	CM20650-33-501
[5]	1783 mm x 850 mm	1739 mm x 806 mm	CM20650-31-501
[6]	1000 mm x 2874 mm	956 mm x 2830 mm	CM20743-12-501

- [7] Setting block – type: Promatect<sup>®</sup>-H – dimensions: 70 mm x 31 mm x 5 mm – density: 960 kg/m<sup>3</sup> (NV).
- number: two per glass pane.
  - position: under the glass panes.
- [8] Glazing bead – material: Meranti – outer dimensions: 27 mm x 25 mm – density: 391 kg/m<sup>3</sup> (MV).
- position: on both sides of the glass panes.
  - fixing:
    - with screws [9] – material: steel – diameter: 4.5 mm – length: 50 mm;
    - centre/centre distance: 200 to 240 mm.
- [10] Glazing strip – material: self-adhesive ceramic paper – brand and type: Superwool X607 – dimensions: 20 mm x 3 mm – density: 210 kg/m<sup>3</sup>.
- position: between the clip-on beads and the glass panes and between the frame and the glass panes.
- [11] Sealant – material: neutral silicone – brand and type: Dow Corning Firestop 700.
- position: sealing between the glazing beads and the glass panes.

#### 1.2.2 Framing system:

The framing system includes the frame components [12]-[14] and the fixing method [15].

- [12] Transoms and mullions – material: Meranti – section dimensions: 33 mm x 91 mm – density: 550 kg/m<sup>3</sup> (NV).
- fixing to the surrounding building structure:
    - with anchors [15] – material: steel – brand and type: Hilti 100 HT – diameter: 10 mm – length: 112 mm;
    - centre/centre distance: 450 mm.
  - fixing of the units to each other:
    - with screws [16] – material: steel – diameter: 5 mm – length: 60 mm;
    - centre/centre distance: 500 mm.
- [13] Intermediate transoms and intermediate mullions – material: Meranti – section dimensions: 46 mm x 91 mm – density: 550 kg/m<sup>3</sup> (NV).
- fixing: glued to the connecting (intermediate)transom or (intermediate)mullion.

- [14] Cover lath – material: Meranti – outer dimensions: 12 mm x 46 mm – density: 550 kg/m<sup>3</sup> (NV).
- position: over the joint between the two units on both sides.
  - fixing:
    - with screws [17] – material: steel – diameter: 3.5 mm – length: 35 mm;
    - centre/centre distance: 300 mm (alternating from edge).
- [18] Setting block – type: Promatect-H – dimensions: 150 mm x 65 mm x 25 mm – density: 960 kg/m<sup>3</sup> (NV).
- position: between the timber frame and the floor connection of the building structure .
  - centre/centre distance: approximately 600 mm.
- [19] Mineral wool – type: Thermal insulation Insulfrax – initial density: 96 kg/m<sup>3</sup> (NV) – compressed to a thickness of approximately 25 mm.
- position: between the timber frame and the surrounding building structure.

## 2 Test report/extended application reports and test results in support of the classification

### 2.1 Test report/extended application reports

Name of the laboratory	Report ref. no.	Name of sponsor	Date of the test	Test method/ Field of extended application rules
WFRGENT nv	14389A	AGC Glass Europe	16/05/2011	EN 1363-1:1999 EN 1364-1:1999
WFRGENT nv	14389C	AGC Glass Europe	16/05/2011	EN 15254-4:2008+A1:2011

#### Exposure conditions during the fire resistance test:

Temperature/time curve: standard as in EN 1363-1:1999.

Direction of exposure:

- The glazing system is asymmetrical: each glass pane is placed with the PVB-layer (44.2) at the exposed side;
- The framing system is symmetrical.

No load is applied.

One vertical edge is free, the other edges are fixed.

## 2.2 Test results

Parameter	Results
<b>Loadbearing capacity</b>	Not applicable
<b>Integrity</b>	
Time of ignition of a cotton pad	No failure at test termination
Time of occurrence of sustained flaming	42 minutes
Time of failure of gap gauge criterion	No failure at test termination
<b>Thermal insulation</b>	
Time after which the mean temperature rise at the unexposed side exceeds 140 °C	13 minutes
Time after which the maximum temperature rise at the unexposed side exceeds 180 °C	14 minutes
<b>Radiation</b>	
Time after which the radiation intensity exceeds 15 kW/m <sup>2</sup>	No failure at test termination
<b>Mechanical action</b>	
No impact test	Not applicable

The test duration was 45 minutes.

### 3 Classification and field of application

#### 3.1 Reference of classification

This classification has been carried out in accordance with clause 7.5.2 of EN 13501-2:2007+A1:2009.

#### 3.2 Classification

The element is classified according to the following combinations of performance parameters and classes as appropriate. No other classifications are permitted.

The classification is valid for the direction of exposure as described in clause 2.1.

**EW 30, EW 20**

**E 30, E 20**

#### 3.3 Direct field of application

This classification is valid for the following end use applications according to EN 13501-2:2007+A1:2009 and EN 1364-1:1999.

The results of the fire test are directly applicable to similar constructions where one or more of the changes listed below are made and the construction continues to comply with the appropriate design code for its stiffness and stability. Other changes are not permitted.

- a) Decrease in the linear dimensions of panes;
- b) Change in aspect ratio of panes, provided that the largest dimension of the pane and its area is not increased;
- c) Decrease in the distance between mullions and/or transoms;
- d) Decrease in distance between fixing centres;
- e) Increase in the dimensions of framing members;
- f) Screwed-on glazing beads, if 'clip-on' beads were incorporated in the test specimen;
- g) Allowances for expansion if none were incorporated in the test specimen;
- h) Change in the angle of installation of up to 10° from the vertical;
- i) Unlimited increase in the width of an identical construction.

### 3.4 Extended field of application

This classification is valid for the following end use applications according to EN 15254-4:2008+A1:2011.

The results of the fire test are directly applicable to similar constructions where one or more of the changes listed below are made. Other changes are not permitted.

The justification and the calculations are given in the extended application report no.14389C.

#### 3.4.1 Exchange of the fire resistant glass

The 'Pyrobelite 7 IGU' glass panes can be replaced by thicker 'Pyrobelite IGU" glass panes, considering the rules listed in extended application report 14389C.

#### 3.4.2 (A)symmetrical fire resistant glass

The fire resistant glass is asymmetrical and can only be used with the PVB-layer (44.2) at the exposed side.

#### 3.4.3 Individual rectangular glass panes : aspect ratio and increase in area

The maximum dimensions of the circular, triangular and four sided shaped glass panes are represented by the thickest lines in annex 6, for the indicated E classifications.

The maximum dimensions of the other non-rectangular glass panes are represented by the thinnest lines in annex 6, for the indicated E classifications.

#### 3.4.4 Individual panes in a wall: radiation

The maximum dimensions of the circular, triangular and four sided shaped glass panes are represented by the thickest lines in annex 6, for the indicated EW classifications.

The maximum dimensions of the other non-rectangular glass panes are represented by the thinnest lines in annex 6, for the indicated EW classifications.



### 3.4.5 Exchange of timber glazing beads

In all cases, the exchange of timber species should be on the basis of density and/or comparative char rate tests (when available), calculations according to EN 1395-1-2 or reference values. These shall demonstrate that the fire performance of the replacement timber bead is either the same or better than that used in the reference test.

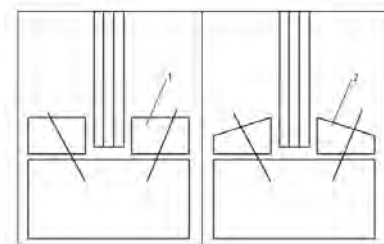

Schematic drawing 1

The bead depth may be increased without restraint: the bead depth must be at least 25 mm.

### 3.4.6 Bead surface coverings

Decorative surface coverings of the glazing beads may be added provided it can be demonstrated that the covering material achieves at least Class A2 when tested according to EN 13501-1. In addition it must be shown that they do not adversely affect the fire performance of the fire resistant glazed element, e.g. in the case of replacement of coverings that provide a contribution to insulation performance.

### 3.4.7 (A)symmetrical framing systems

The framing system is completely symmetrical and can be used in both directions.

### 3.4.8 Exchange of frames

Frames can be manufactured using some or all of the following allowed junction types:

Type A is allowed: four panes joining together;

Type B is allowed: three panes joining together at one point including a full height vertical pane;

Type C is allowed: three panes joining together at one point including a full width horizontal pane;

Type D is not allowed: two full panes side by side (horizontal and vertical);

Type E is allowed: corner junction.

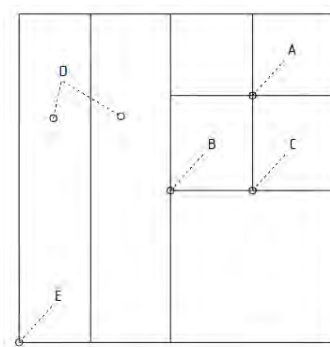

Schematic drawing 2

#### 3.4.9 Timber frames

Exchange of the type of timber species used for the frame is allowed for fire resistant glass from the same glass product group as follows:

- Timber with the same or higher density and/or moisture content, with the same or lower char rate and identical profile: the density must have at least a nominal value of 550 kg/m<sup>3</sup>;
- Increased thickness of the frame: the thickness of the frame must be at least 91 mm.

#### 3.4.10 Frame surface coverings

Decorative surface coverings of the framing members may be added provided it can be demonstrated that the covering material achieves at least Class A2 when classified according to EN 13501-1. In addition it must be shown that they do not adversely affect the fire performance of the fire resistant glazed partition, e.g. in the case of replacement of coverings that provide a contribution to insulation performance.

#### 3.4.11 Increase in overall dimensions and area of the glazed partition

The maximum dimensions of the fire resistant glazed partition are represented by the thickest lines in annex 7, for the indicated E classifications.

#### 3.4.12 Increase in dimensions for fire glazed partitions: radiation

The maximum dimensions of the fire resistant glazed partition are represented by the thickest lines in annex 7, for the indicated EW classifications.

#### 3.4.13 Replication of the fire resistant glazed partition

A wider construction achieved by replicating the fire resistant glazed partition as tested, by adding more units of the same fire resistant glazed partition side by side is allowed for all the classifications listed in §3.2.

#### 3.4.14 Changing in installation angle

A change in the angle of installation of up to +/- 10 degrees from the vertical is allowed. No further increase in the installation angle is allowed.

#### 4 Duration of the validity of the classification report

At the time the standard EN 13501-2:2007+A1:2009 was published, no decision was made concerning the duration of validity of the classification document.

#### 5 Warning

This classification document does not represent type approval nor certification of the product.

SIGNED

APPROVED

This document is the original version of this classification report and is written in English.

This report may be used only literally and completely for publications. - For publications of certain texts, in which this report is mentioned, our permission must be obtained in advance.

The authenticity of the electronic signatures is assured by Belgium Root CA.

Front view (unexposed side) – dimensions.

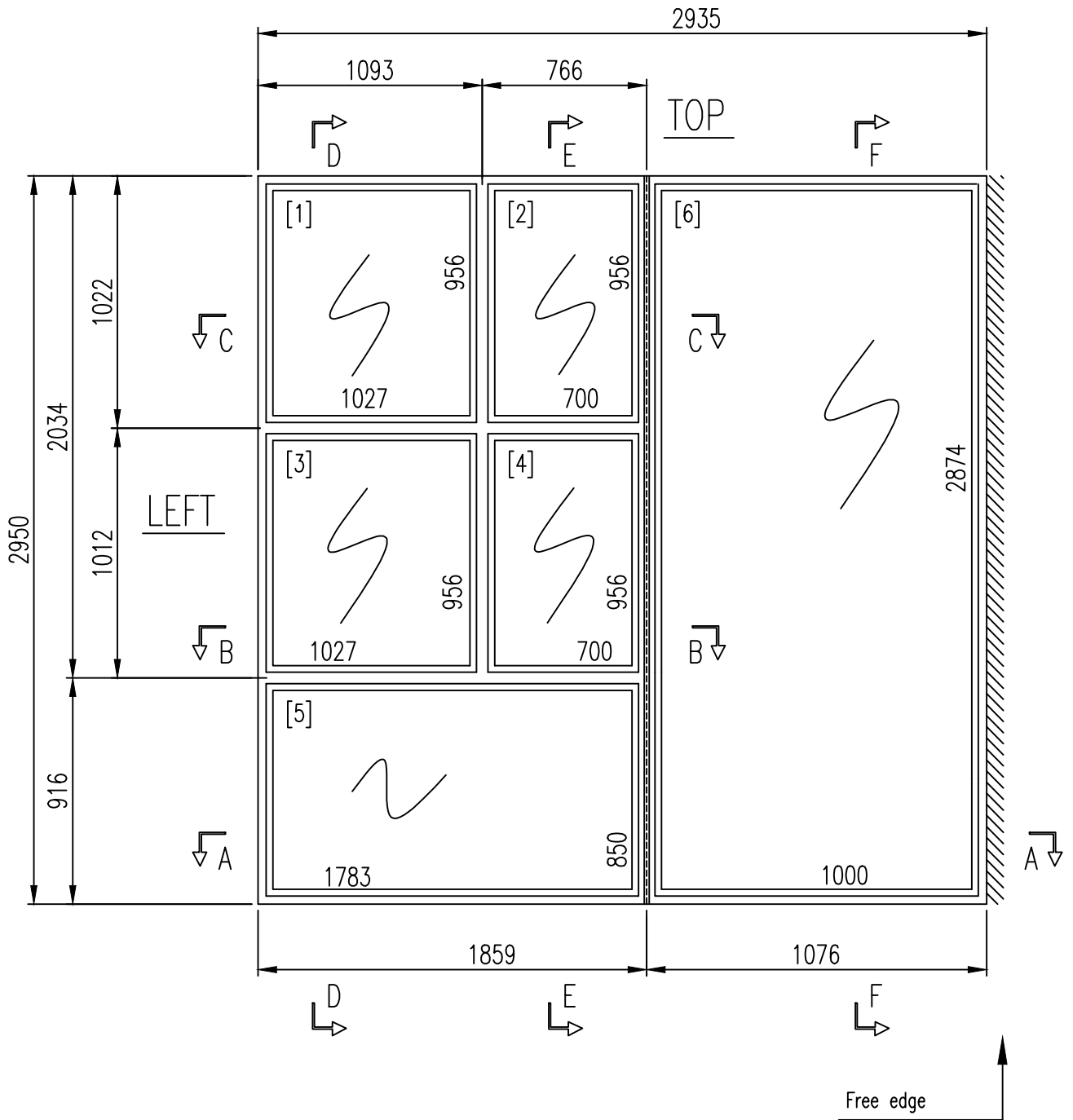

Section AA:

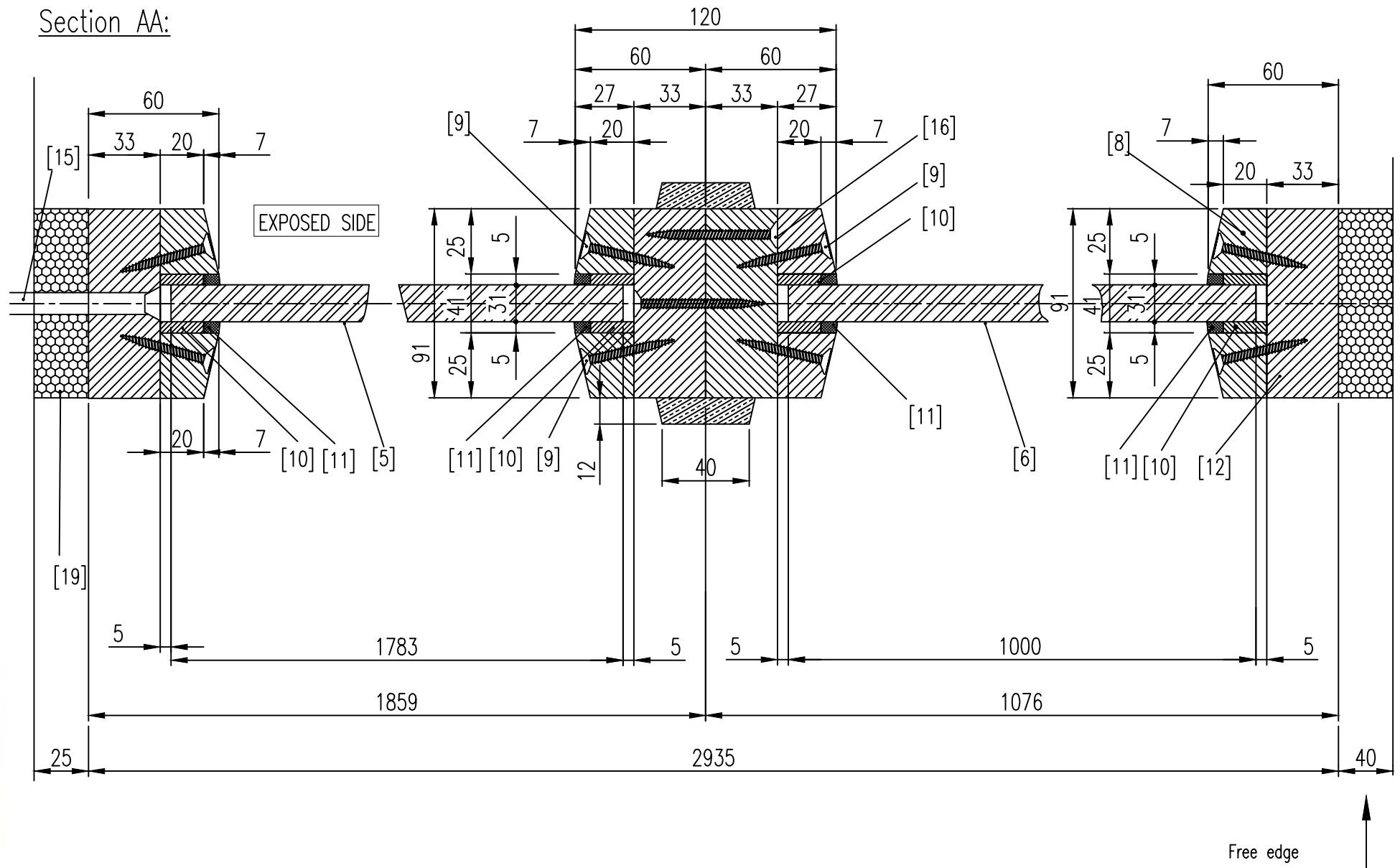

Sections BB and CC:

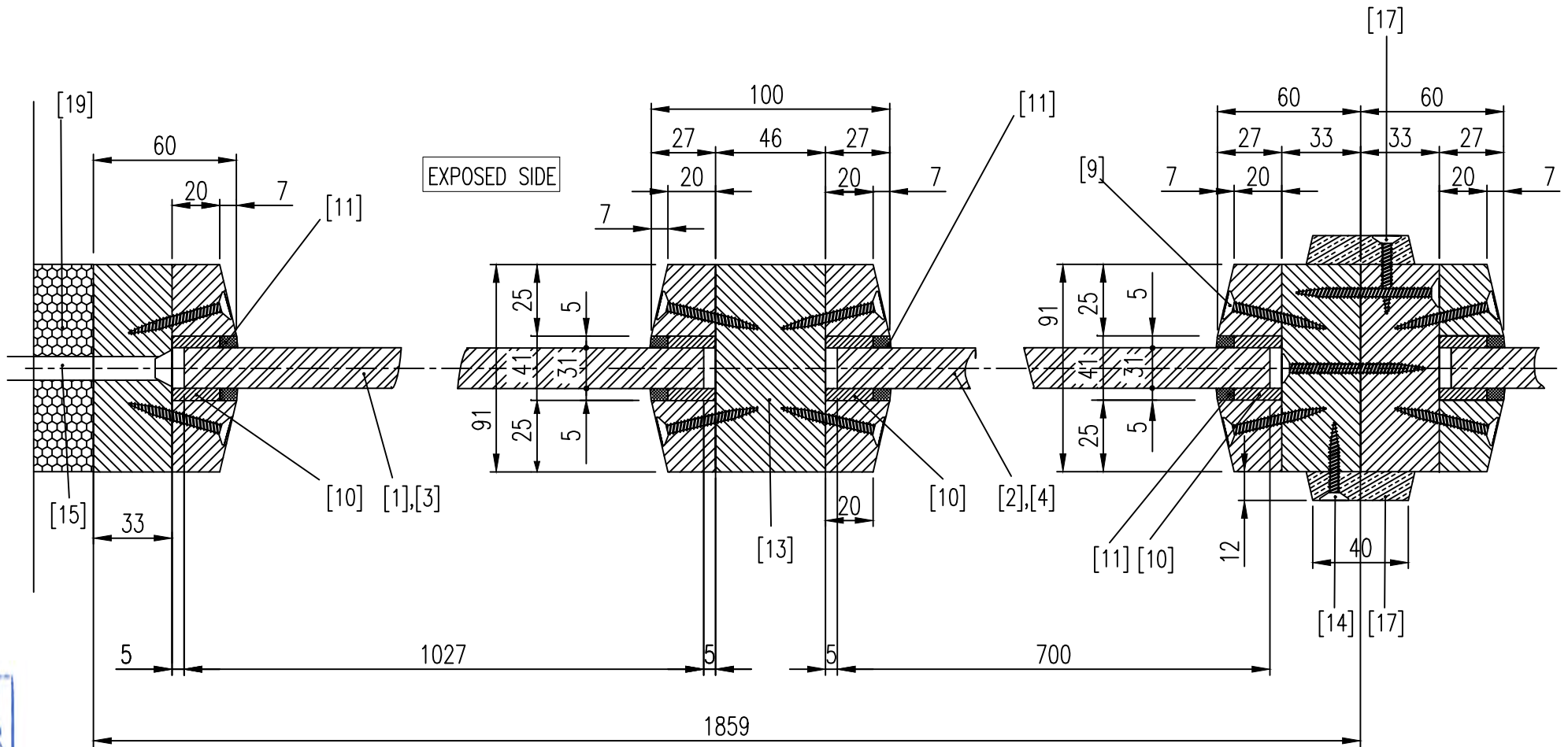

Sections DD and EE:

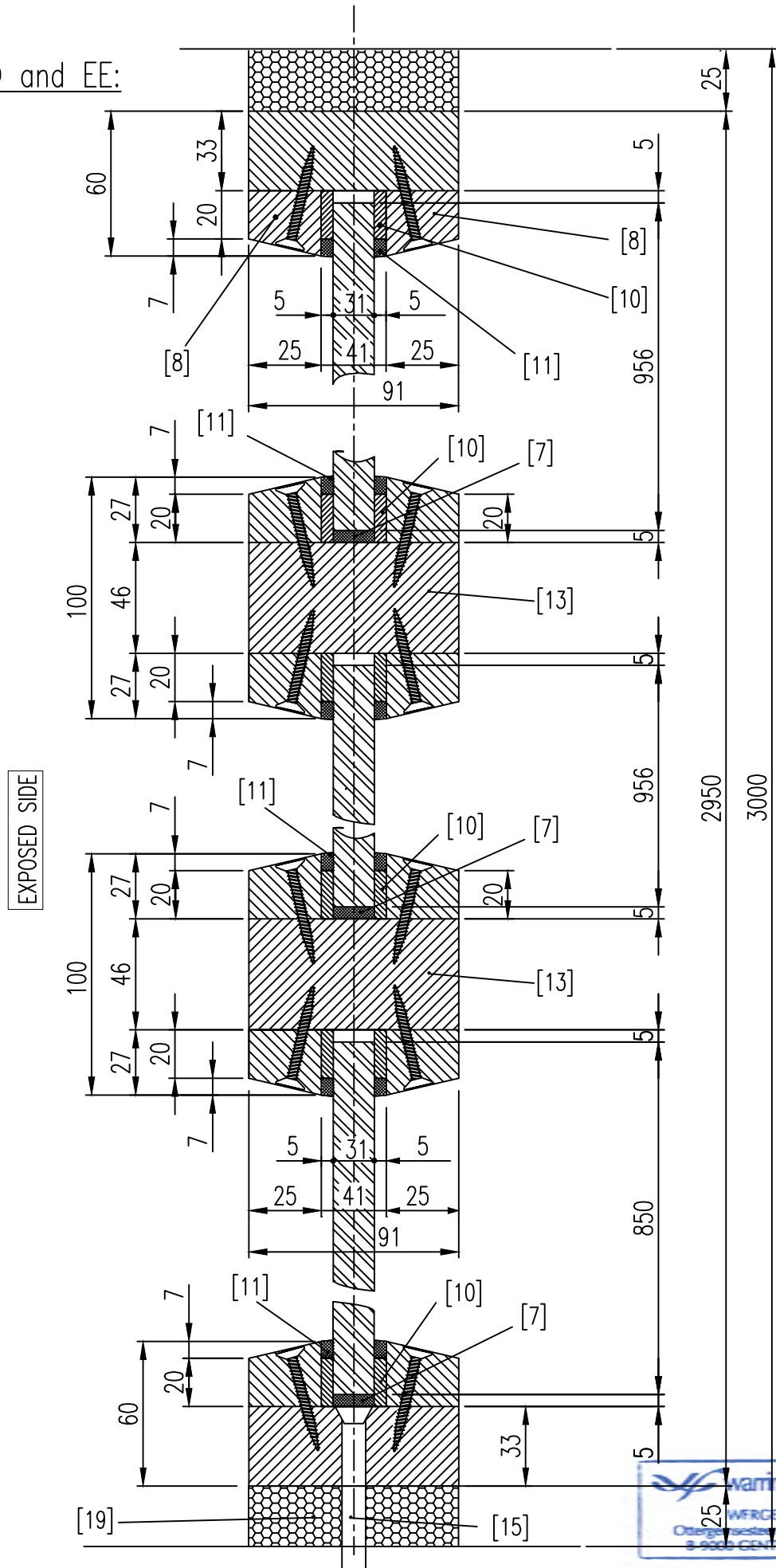

Section FF:

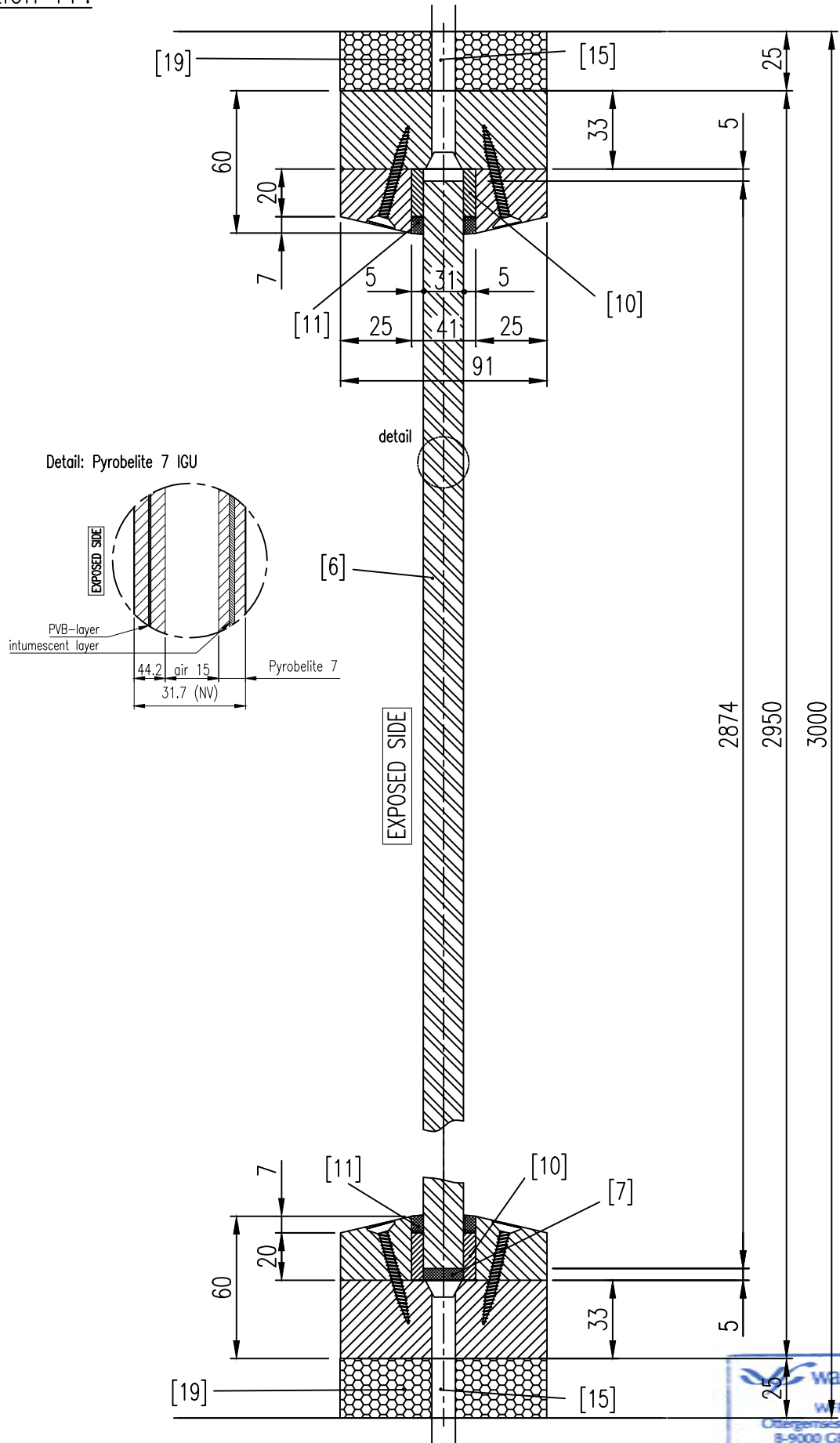



**Individual rectangular glass panes: aspect ratio and increase in area**

The extended dimensions are only valid for the following classifications:

- E 30, E 20;
- EW 30, EW 20.

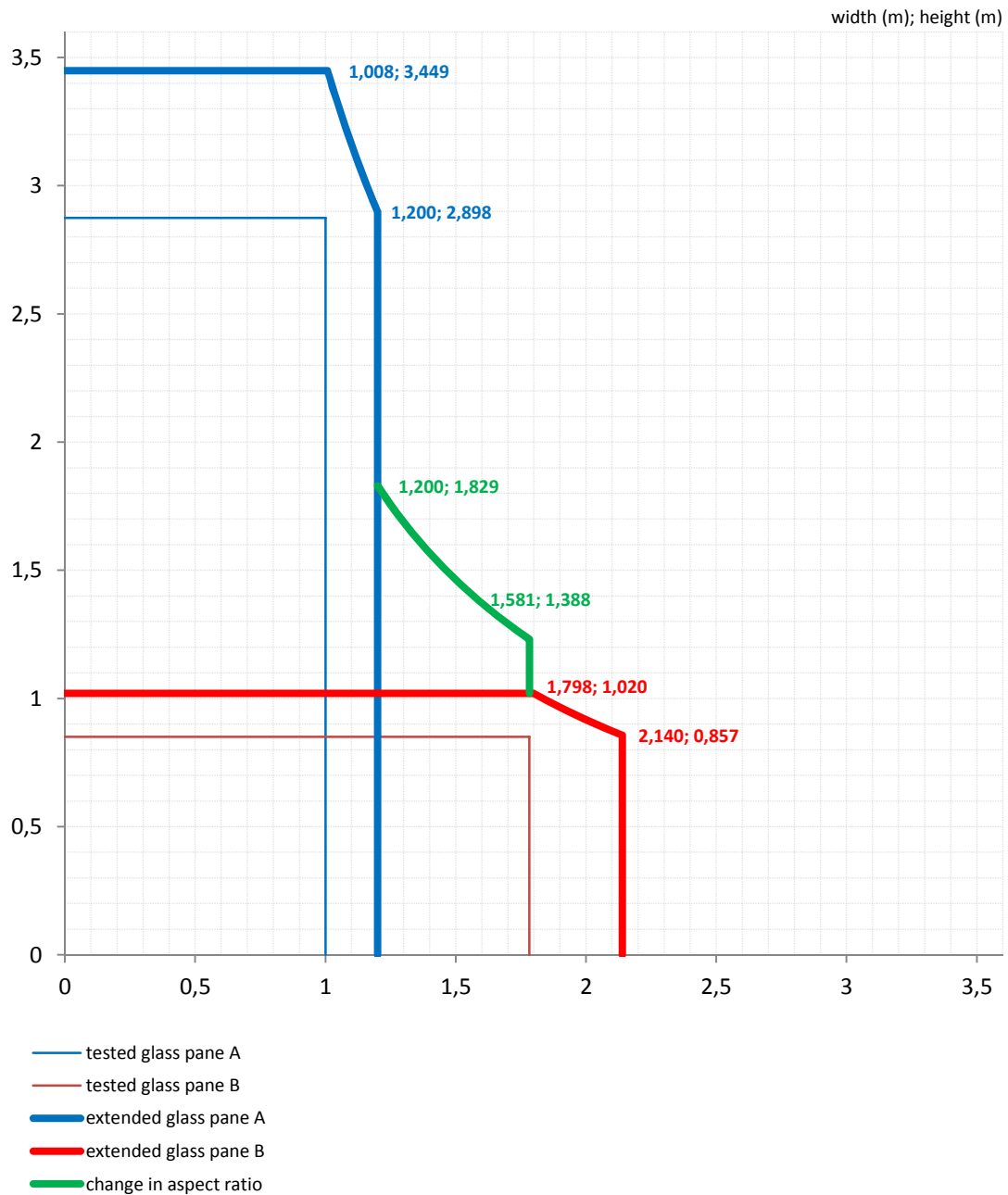

**Note:**

The maximum dimensions of circular, triangular and four sided shaped glass panes are represented by the thickest lines (extended dimensions). The maximum dimensions of the other non rectangular glass panes are represented by the thinnest lines (tested dimensions).

**Increase in overall dimensions and area of the partition**

The extended dimensions are only valid for the following classifications:

- E 30, E 20;
- EW 30, EW 20.

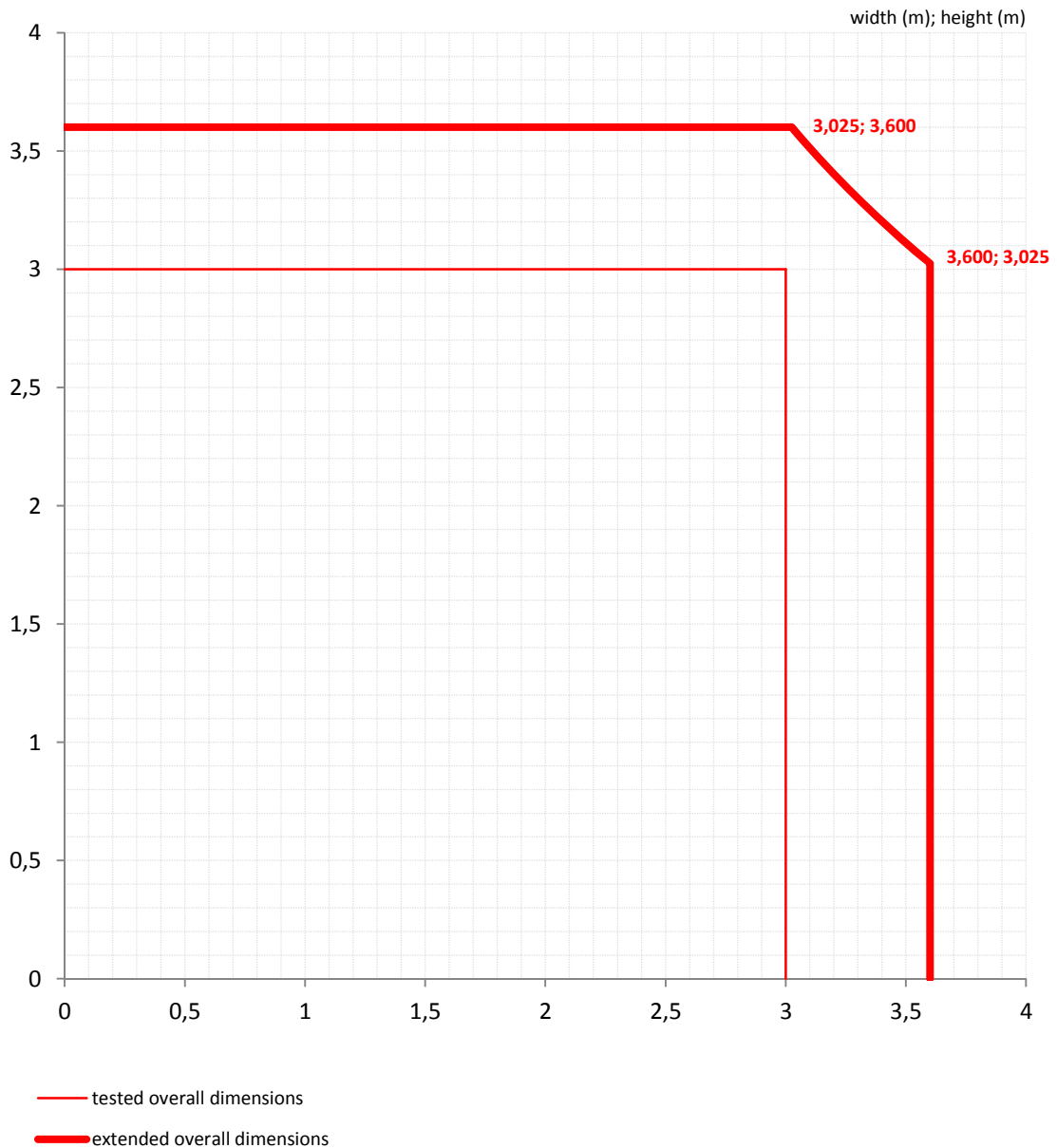

**Note:**

The maximum overall dimensions of the fire resistant glazed partition are represented by the thickest lines. A wider construction achieved by replicating the extended fire resistant glazed partition is allowed.